

## GROUP A

*Answer ALL questions*

1. Suppose you are given with a sequence of  $n$  integers. Write a program (using pseudo-code) that will efficiently find out a pair of indices  $i$  and  $j$  ( $i \leq j$ ) such that the product of the values in the sub-sequence starting at index  $i$  and ending at index  $j$  (both inclusive) is the minimum. Consider the starting index to be 0. You need to output both the indices and the minimum value of product. In case, there are multiple subsequences possible as the optimal answer, return the shorter subsequence. If there is a further tie return all the results. [8]
2. Find the purposes of the following pieces of conditional checks.
  - (a) if  $m \& (m - 1) \neq 0$ , for any arbitrary integer  $m$ .
  - (b) if  $(m \wedge n) < 0$ , for any arbitrary pair of integers  $m$  and  $n$ .

NOTE: The operators ‘&’ and ‘ $\wedge$ ’ denote the standard bitwise AND and bitwise OR, respectively. [2+2]

3. There are seven greeting cards, each of a different color, and seven envelopes of the same seven colors. Find the number of ways in which the cards can be put in the envelopes, so that exactly four of the cards go into the envelopes of the right colors. [6]
4. Let 10% of all the phone calls that you receive over the period of a day are advertisement calls (AD). Your DND (do not disturb) facility is 90% reliable, that is, 90% of the calls it labels as AD are indeed AD calls and 90% of AD calls are correctly labelled as AD. If one of your incoming calls is labelled AD by the DND facility, what is the probability that it is really an AD call? [6]
5. In how many ways can someone list the numbers  $0, 1, \dots, n$  such that apart from the leading element, a number  $t$  can be placed only if either  $(t + 1)$  or  $(t - 1)$  already appears. [6]

## GROUP B

Answer FIVE questions from any one of the following sections

### COMPUTER SCIENCE

1. Let  $A$  be an array of  $n$  integers containing the numbers  $\{1, 2, \dots, n\}$  in some arbitrary order. For integers  $i$  and  $j$  such that  $1 \leq i < j \leq n$ , let  $\text{REVERSE}(A, i, j)$  be a procedure that reverses the subarray  $A[i], A[i + 1], \dots, A[j]$  of the array  $A$  while leaving the remaining elements of the array unaffected. Prove that the following algorithm sorts the array  $A$  and also terminates.

```
for  $i := 1$  to  $n - 1$ 
    while  $A[i] \neq i$  do
        REVERSE( $A, i, A[i]$ ).
```

[10+4]

2. Consider a hard disk whose storage space  $S$  is divided into a number of logical sectors (segments) of equal length  $l$ . Consecutive requests for storing data into it are served in such a way that no piece of data is fragmented to accommodate the same over more than one sectors under the assumption that the length of each piece of data is less than the sector size and a single sector can accommodate multiple pieces of data. Write an algorithm to store a given sequence of  $m$  consecutive storage requests  $\{s_1, s_2, \dots, s_m\}$  using the minimum number of sectors, where  $s_i$  is the size of  $i$ -th data request,  $s_i < l$ , for each  $i$  and  $\sum_i s_i < S$ . For example, consider the sequence of data storage requests  $\{2\text{kb}, 5\text{kb}, 4\text{kb}, 7\text{kb}, 1\text{kb}, 3\text{kb}, 8\text{kb}\}$  into a hard disk of sector length 10. The minimum number of sectors required for the storage is 3 and a possible distribution of the data pieces into 3 sectors are  $\{2\text{kb}, 8\text{kb}\}$ ,  $\{5\text{kb}, 4\text{kb}, 1\text{kb}\}$  and  $\{7\text{kb}, 3\text{kb}\}$ . Similarly, the data storage request  $\{4\text{kb}, 8\text{kb}, 1\text{kb}, 4\text{kb}, 2\text{kb}, 1\text{kb}\}$  into the same hard disk can be met using 2 sectors with the corresponding distributions of the data pieces as  $\{8\text{kb}, 2\text{kb}\}$ ,  $\{4\text{kb}, 4\text{kb}, 1\text{kb}, 1\text{kb}\}$ .  
[14]
3. Memory address decoding is necessary for mapping the address space of processor to the address space of memory. Consider an  $n$ -bit (assume that  $n$  is even) address register to access a memory of size  $2^n$ . Instead

of a single decoder with  $n$ -bits input, if one uses two decoders of inputs of size  $k$ -bits and  $(n - k)$ -bits, respectively, will there be any advantage in address decoding time? What will be the optimal value of  $k$  for minimizing the address decoding time? Note that, you may assume any suitable memory layout. [8+6]

4. Let us consider a household, as shown in Figure 1, with two lights. One of these lights is at porch gate and the other is inside the room. The lights are controlled by three switches A, B and C; out of which two are inside the house and one is outside the house. Both the lights are OFF when all the switches are OFF. Both the lights are ON when all the three switches are ON. If any two switches are ON then the porch light is ON. If only one of A, B and C are ON then the light inside the room is ON. Design a circuit using only NAND gates to realize this. [14]

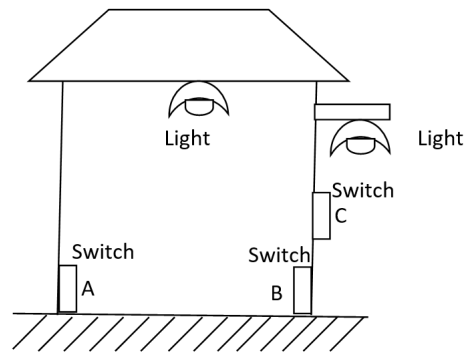

Figure 1: A household with a pair of lights.

5. Let us consider the relation schema  $\langle \text{CTHRSG} \rangle$ , where the attributes are  $C \equiv \text{Course}$ ,  $T \equiv \text{Teacher}$ ,  $H \equiv \text{Class Hour}$ ,  $R \equiv \text{Classroom}$ ,  $S \equiv \text{Student}$ ,  $G \equiv \text{Grade}$ . We assume the following:
- Each course is taught by one teacher.
  - Only one course can be taught in a classroom at one time.
  - A teacher can be in only one classroom at one time.
  - Each student has one grade in each course.
  - A student can be in only one classroom at one time.
- (a) Write down the above statements in terms of functional dependencies.
- (b) Determine a key for the schema  $\langle \text{CTHRSG} \rangle$ .

- (c) Check whether the schema  $\langle CTHRSG \rangle$  is in BCNF or not. If not, decompose it into the schemas which are in BCNF.
- (d) Justify whether the above decomposition is dependency preserving or not.

[5+2+(1+4)+2]

6. Figure 2 pictorially shows the layout of a file descriptor of a file system. It uses 4 direct, 1 indirect, and 1 doubly indirect block addresses. If the size of a disk block is 64 bytes and the size of each disk block address is 8 bytes, calculate the maximum possible file size for this file system. Give the answer in the form of " $a \times 2^A$ ". [14]

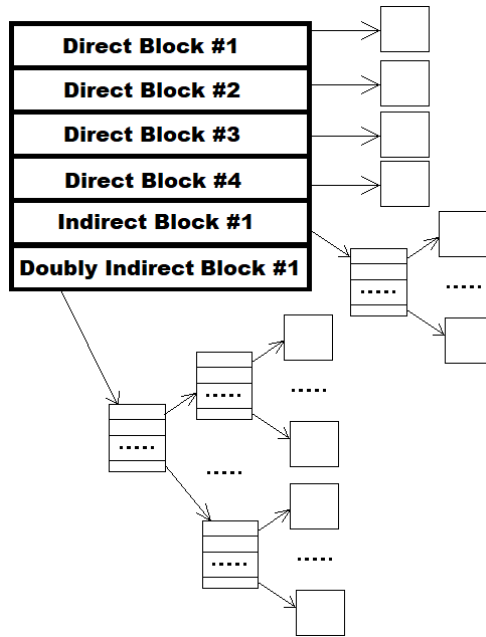

Figure 2: A file system with direct and indirect blocks.

7. (a) Consider an alphabet  $\{0, 1, \dots, 9\}$ . Design a Deterministic Finite Automaton (DFA) that accepts strings whose decimal equivalent are divisible by 3.
- (b) Using Pumping Lemma, prove that the language  $\{a^p : p \text{ is prime}\}$  is not regular.

[7+7]

8. Recall the stop-and-wait and sliding window protocols for a packet-based data transmission protocol. The stop and wait protocol sends one packet and waits for the acknowledgment to arrive. The waiting mechanism does waste network bandwidth. In order to improve the bandwidth utilization, the sliding window protocol utilizes pipelined communication where multiple packets are sent before needing the acknowledgements. Since multiple packets are sent, each packet is stamped with a sequence number. The idea of using sequence number in each packet helps the sender to decide whether it continues transmission or waits for acknowledgement; and the receiver to arrange the packets in order and to prepare acknowledgements.

Consider that a sliding window protocol is used for data transmission between two stations, say  $P$  and  $Q$ , located at a distance of  $D$  km. All packets are  $k$  bits long. The propagation delay is  $t$  s/km. The channel capacity (in bits/sec) is  $B$ . Calculate the minimum number of bits required for the sequence number field in a packet for maximum utilization of the bandwidth. Assume that the processing delay is negligible. [14]

## ELECTRICAL AND ELECTRONICS ENGINEERING

1. Consider a hypothetical gate  $G(A, B, C)$  for which the Karnaugh map is given in Figure 3.

		AB			
		00	01	11	10
C	0	0	0	1	0
	1	0	1	0	1

Figure 3: The Karnaugh map for the hypothetical gate  $G$ .

- (a) Implement the standard AND, OR and NOT operations using minimum number of  $G$  gates.
- (b) Consider the switching function  $f(w, x, y, z)$  defined as follows

$$f(w, x, y, z) = \sum(0, 1, 2, 4, 7, 8, 9, 10, 12, 15).$$

Realize  $f$  by means of minimum number of  $G$  gates.

[6+8]

2. A binary string of length  $k$  has to be communicated through a noisy channel. It is known that the number of errors  $N$  (if the actual message is 00110 and the transmitted message is 01111, then the number of errors is 2) produced by the channel follows the probability distribution:

$$P(N = i) = \frac{1}{2^{i+1}}, i \geq 0.$$

Show that there exists a binary encoding function  $E : \{0, 1\}^k \rightarrow \{0, 1\}^n$  that can be perfectly decoded with probability at least  $\frac{3}{4}$ , only when  $n$  satisfies:

$$n - \log_2(1 + n) \geq k.$$

[14]

3. Let  $H(x) = -x \log_2(x) - (1-x) \log_2(1-x)$  denote the Shannon's entropy function and  $0 < p < 0.5$  be an arbitrary value. Let  $d$  denote the Hamming distance on  $\{0, 1\}^n$ . Recall that Hamming distance between

two strings is the number of positions in which the strings differ. For example, the Hamming distance between 1100 and 1001 is 2. For  $x \in \{0, 1\}^n$ , the Hamming ball of radius  $r$  is given by

$$B(x, r) = \{y \in \{0, 1\}^n | d(x, y) \leq r\}.$$

Show that the number of elements in  $B(x, np)$  satisfies the inequality:

$$|B(x, np)| \leq 2^{nH(p)}.$$

[14]

4. In a series-parallel circuit, as shown in Figure 4, the parallel branches A and B are in series with C. The impedances are given by  $Z_A = (2 + j2)\Omega$ ,  $Z_B = (2 - j2)\Omega$ , and  $Z_C = (2 + j2\sqrt{3})\Omega$ . If the current through  $Z_C$  is  $I_C = (25 + j0)$ . Draw the complete phasor diagram showing the branch currents and voltages and the total voltage. Also compute the power of each branch and the whole circuit. Note that,  $\tan^{-1}(\frac{\sqrt{3}}{2}) = 41^\circ$ . [14]

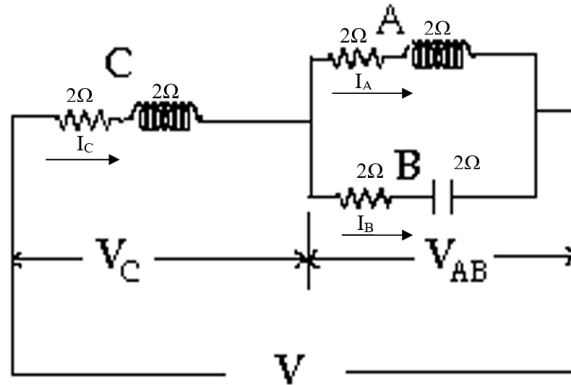

Figure 4: A series-parallel circuit.

5. Solve the following initial value problems using Laplace transform:

- (a)  $\frac{dy}{dt} + \frac{y}{2} = 17 \sin(2t)$ ,  $y(0) = -1$ .  
 (b)  $\frac{d^2y}{dt^2} = \begin{pmatrix} -3 & -2 \\ 4 & 3 \end{pmatrix} y$ ,  $y(0) = \begin{pmatrix} 1 \\ 0 \end{pmatrix}$ ,  $y'(0) = \begin{pmatrix} 0 \\ 1 \end{pmatrix}$ .

[6+8]

6. (a) A system is given by the difference equation  $y(n) = ny(n-1) + x(n)$  for  $n \geq 0$ , and  $y(-1) = 0$ . Is the system linear and time invariant? Does it produce bounded output in response to bounded input? Justify your answer in each case.

- (b) Another system is given by the difference equation  $y(n) = ay(n-1) + bx(n)$ , which also satisfies the condition  $\sum_{n=-\infty}^{\infty} h(n) = 1$ , where  $\{h(n)\}_{n=-\infty}^{\infty}$  are the impulse response of the system. What can you tell about the values of  $a$  and  $b$ , that is, are they related by a functional relationship or they are independent? In case there is a functional relationship please give the explicit form of the relationship.
- (c) State with justification whether an infinite impulse response (IIR) system given by the following system function is stable:

$$H(z) = \frac{1 + 2z^{-1} + 3z^{-2} + 2z^{-3}}{1 - 9z^{-1} + 26z^{-2} - 24z^{-3}}$$

[(3+2+2)+4+3]

7. (a) Show that  $\sin(x)$ ,  $\cos(x)$  and  $x$  are linearly independent for  $0 < x \leq 2\pi$ .
- (b) Let  $[x(n)]_{n=-\infty}^{\infty}$  be an infinite duration discrete signal, which was sampled from a continuous signal at sample frequency  $f_s = 20$  kHz. The continuous signal was band limited to 10 kHz. A block of 256 samples was chosen as

$$\hat{x}[n] = \begin{cases} x[n], & 0 \leq n \leq 255, \\ 0, & \text{otherwise.} \end{cases}$$

The block signal was transformed by DFT to  $\hat{x}[k]$ ,  $k = 0, \dots, 255$ . What are the continuous time frequencies in Hertz corresponding to the DFT indices of  $k = 32$  and  $k = 231$ ? Show the complete derivation.

[6+(4+4)]

8. Suppose a single phase 10 KVA transformer delivers full load at 0.81 power factor with 90% efficiency. If the same transformer works at 80% of the full load at 0.8 power factor, its efficiency decreases to 80%.
- (a) Calculate the iron loss of the transformer.
- (b) The transformer has 200 turns at primary winding while 10 turns at the secondary windings. Neglecting any loss, determine the current in secondary winding given the primary voltage is 220V and the secondary winding is connected to a load of  $11 \Omega$ .

[6+8]



## MATHEMATICS

1. (a) Suppose that  $V$  is a 4-dimensional vector space over  $\mathbb{R}$ . Let  $T : V \rightarrow V$  be an invertible linear map and  $W$  be a proper subspace of  $V$ , such that

$$V = W \oplus TW.$$

If  $T^2W \subseteq W$ , then show that  $T^2W = W$ .

- (b) Suppose that  $A$  and  $B$  are two  $n \times n$  real symmetric matrices and  $A$  is also non-negative definite. Show that all eigenvalues of the matrix  $AB$  are real.

[4+10]

2. An urn contains one red ball, one green ball and two black balls. Balls are drawn at random from the urn, one after another and put back in the urn after noting its colour. For a natural number  $n \geq 3$ , calculate the probability that it takes exactly  $n$  draws to get at least one ball of each of the three colours.

[14]

3. (a) Let  $p$  and  $q$  be distinct primes and  $m = p^q + q^p$ . What is the remainder if  $m$  is divided by  $pq$ ?
- (b) Let  $W = \{(x_1, x_2, x_3, x_4, x_5) \in \mathbb{R}^5 \mid x_1 = x_2, x_3 = x_4 = x_5\}$  be the subspace of  $\mathbb{R}^5$ . Find the dimension of  $W$ .  
Prove that there does not exist a linear map  $T$  from  $\mathbb{R}^5$  to  $\mathbb{R}^2$ , such that its null space  $N(T) = W$ .

[9+5]

4. Let  $C$  be a closed, symmetric (i.e., if  $x \in C$  then  $-x \in C$ ) convex subset of  $\mathbb{R}^n$  such that

$$\bigcup_{m \in \mathbb{N}} mC = \mathbb{R}^n, \text{ where } mC = \{mx \mid x \in C\}.$$

Prove that there exists  $r > 0$  such that

$$B(0, r) = \{x \in \mathbb{R}^n \mid \|x\| < r\} \subseteq C.$$

[14]

5. (a) Show that a connected subset of a metric space is either a singleton or uncountable.
- (b) Let  $A$  be a connected subset of a connected topological space  $X$ . Suppose that  $B$  is a clopen (closed and open) subset of  $X \setminus A$  in the subspace topology of  $X \setminus A$ . Prove that  $A \cup B$  is connected.

[4+10]

6. (a) Let  $G$  be a finite group. Assume that  $G$  has exactly one element  $a$  of order 2. Then show that

$$\prod_{g \in G} g = a.$$

- (b) Let  $G$  be a group. Let  $a$  and  $b$  be two elements of  $G$  such that both have finite orders. Is the order of  $ab$  always finite? Justify your answer.
- (c) Justify whether a group of order 48 is simple or not.

[3+5+6]

7. (a) Let  $R = \{f : [0, 1] \rightarrow \mathbb{R} \mid f \text{ is continuous}\}$  be a ring. In  $R$ , consider the ideal  $I = \{f \in R \mid f(\frac{1}{2}) = 0 = f(\frac{1}{3})\}$ . Verify whether  $I$  is a prime ideal.
- (b) Let  $R$  be a commutative ring with unity and  $P$  be a prime ideal of  $R$  such that  $P$  does not contain any non-zero zero-divisor. Show that  $R$  is an integral domain.
- (c) Determine whether  $X^6 + 4X^3 + 1$  is irreducible in  $\mathbb{Q}[X]$ .

[4+4+6]

8. (a) Let  $k$  be a field and  $\alpha$  be transcendental over  $k$ . Let  $E (\neq k)$  be a field such that

$$k \subsetneq E \subseteq k(\alpha).$$

Prove that  $k(\alpha)$  is a finite extension of  $E$ .

- (b) Let  $k$  be a field of characteristic not equal to 2. Let  $a, b \in k$  be such that neither  $a$  nor  $b$  is a square in  $k$ . Prove that  $k(\sqrt{a}, \sqrt{b}) = k(\sqrt{a} + \sqrt{b})$ . Also show that the degree of  $k(\sqrt{a}, \sqrt{b})$  over  $k$  is 2, if  $ab$  is a square in  $k$ ; and it is 4, if  $ab$  is not a square in  $k$ .

[5+(3+6)]

## PHYSICS

1. (a) Assume that the solar system is immersed in a uniform dust of constant density  $\rho$ . Also consider that the sun is infinitely heavy with respect to the earth.
  - i. Construct the Lagrangian for the motion of the earth. Assume that the potential vanishes at infinity.
  - ii. Give an expression to derive the radius of a circular orbit.
- (b) Find  $r$ -dependence of the central forces for which the trajectories of a particle of mass  $m$  moving under those forces are given in polar form by
  - i.  $r^n = a^n \cos n\theta$
  - ii.  $r = a(1 + \cos \theta)$where  $a$  is a constant.

[(4+3)+(4+3)]

2. (a) A steady current flows down a long cylindrical wire of radius  $R$ . Find the magnetic field, both inside and outside the wire, if
  - i. the current is uniformly distributed over the outside surface of the wire,
  - ii. the current is distributed in such a way that the volume current density is proportional to the distance from the axis.
- (b) A perfectly conducting spherical shell of radius  $R$  rotates about the  $z$ -axis with angular velocity  $\omega$ , in a uniform magnetic field  $\vec{B} = B_0 \hat{z}$ . Calculate the *emf* developed between its 'north pole' and the 'equator'.

[(3+5)+6]

3. (a) Find the capacitance per unit length of two coaxial metal cylindrical tubes, of radii  $a$  and  $b$  ( $a < b$ ). Assume that the inner tube is at a higher potential.
- (b) The electric fields outside and inside of a solid sphere of radius  $R$  with a uniform volume charge density are given by  $\vec{E}_{r>R} = \frac{1}{4\pi\epsilon_0} \frac{q}{r^2} \hat{r}$  and  $\vec{E}_{r<R} = \frac{1}{4\pi\epsilon_0} \frac{qr}{R^3} \hat{r}$ , respectively, while the electric field outside of a spherical shell with uniform surface charge density is given by  $\vec{E}_{r>R} = \frac{1}{4\pi\epsilon_0} \frac{q}{r^2} \hat{r}$ , where  $q$  is the total charge. Determine the ratio of the electrostatic energies for the spherical shell to the solid sphere.

- (c) At equilibrium, there cannot be any free charge inside a metal. However, if we forcibly put charge in the interior then it takes some finite time to disappear, i.e., move to the surface of the metal. Calculate the time to disappear. Assume the conductivity  $\sigma$  of the metal is  $10^6 (\Omega\text{m})^{-1}$  and the dielectric constant  $\epsilon_0 = 8.85 \times 10^{-12}$  Farad/m.

[6+5+3]

4. (a) A particle is in the first excited state of a one dimensional box of length  $L$ . Suddenly the box expands to twice its size, leaving the wave function undisturbed. Calculate the probability of finding the particle in the ground state under measurement of Hamiltonian observable.
- (b) i. Determine the eigenvalues and eigenvectors of the spin operator  $\vec{S}$  of an electron in the direction of a unit vector  $\vec{n}$ . Assume that  $\vec{n}$  lies in the  $xz$  plane.
- ii. Evaluate the probability of measuring  $\hat{S}_z = +\hbar/2$ .

[5+(5+4)]

5. At room temperature,  $k_B T/e = 26$  mV (the symbols carry their usual meaning). A sample of cadmium sulfide displays a mobile carrier density of  $10^{16} \text{ cm}^{-3}$  and a mobility coefficient  $\mu = 10^2 \text{ cm}^2/\text{volt sec}$ .
- (a) Find the electrical conductivity of this sample.
- (b) The carriers are continuously trapped into immobile sites and then being thermally reionized into mobile states. If the average free lifetime in a mobile state is  $10^{-5}$  sec, what is the *rms* distance a carrier diffuses between successive trappings?
- (c) If the charge carriers have an effective mass equal to 0.1 times the mass of a free electron, what is the average time between successive scatterings?

[4+6+4]

6. Take a system of  $N = 2 \times 10^{22}$  electrons in a “box” of volume  $V = 1 \text{ cm}^3$ . The walls of the box are infinitely high potential barriers. Calculate the following within a factor of five and show the dependence on the relevant physical parameters:
- (a) specific heat  $C$ ,
- (b) magnetic susceptibility  $\chi$ ,
- (c) average kinetic energy  $\langle E_k \rangle$ ,

(d) pressure on the walls of the box  $p$ .

[5+3+3+3]

7. Consider a Lagrangian for a charged scalar field  $\phi(x)$  with an interaction term  $\lambda(\phi^*\phi)^3$  with  $\lambda$  and  $m$  being the coupling constant and mass parameter, respectively.

- (a) Write down the equations of motion.
- (b) Derive the expression for the charge current and show that it is conserved.
- (c) How can you introduce electromagnetic interactions in a gauge invariant way? Derive the equations of motion for the electromagnetic field.

[3+5+6]

8. (a) The universal speed of light  $c$  assumes vacuum as its medium of propagation. When light moves in a stationary transparent medium, its velocity  $v_m$  slows down by a factor  $n$ , called the refractive index of the medium, so that  $v_m = \frac{c}{n}$ . Suppose the medium moves with speed  $v$  with respect to a stationary observer in the lab frame. Show that for small  $v$ , the speed of light  $v'$  as measured by the stationary observer in the lab frame, is approximately

$$v' \approx \frac{c}{n} + v \left( 1 - \frac{1}{n^2} \right).$$

(b) Explain why the following processes are not observed in nature. The symbols carry their usual meaning.

$$\mu^+ \rightarrow e^+ + \gamma$$

$$\Lambda^0 \rightarrow K^0 + \pi^0$$

$$\Lambda^0 \rightarrow K^+ + K^-$$

$$p \rightarrow e^+ + \pi^0$$

$$p + \bar{p} \rightarrow \Lambda^0 + \Lambda^0$$

$$p \rightarrow e^+ + \nu_e$$

$$n \rightarrow p + e^-$$

[7+7]

## STATISTICS

1. An urn contains  $r$  ( $> 0$ ) red balls and  $b$  ( $> 0$ ) black balls. One ball is drawn at random from the urn and the ball drawn is returned to the urn with  $c$  ( $> 0$ ) many additional balls of its colour. Thus, there are  $r + b + c$  balls in the urn after the first draw. The process is repeated. Let  $X_i$  be a random variable which equals 1 if the  $i$ -th ball drawn is red and  $X_i = 0$  if the  $i$ -th ball drawn is black.

- (a) Find the distribution of  $(X_1, X_2, X_3)$ .  
(b) Show that the distribution of  $(X_2, X_1, X_3)$  is same as that of  $(X_1, X_2, X_3)$ .  
(c) What is the distribution of  $(X_3, X_2, X_1)$ ? Give reasons.  
(d) Find  $\text{Cov}(X_1, X_3)$ . [4+4+2+4 = 14]

2. Let  $X_1, \dots, X_n$  be a sequence of independent and identically distributed (i.i.d.) random variables such that  $E(|X_1|)^4 < \infty$ . Let  $E(X_1) = \mu$ . Let  $Y_n \stackrel{\text{def}}{=} \frac{1}{n} \sum_{i=1}^n X_i$ ,  $n \geq 1$ .

- (a) Prove that for every  $\varepsilon > 0$ ,

$$\sum_{n=1}^{\infty} P(|Y_n - \mu| > \varepsilon) < \infty.$$

- (b) Hence, or otherwise, show that  $Y_n$  converges almost surely to  $\mu$ . [9+5 = 14]

3. Let  $X_1, X_2, \dots, X_n$  be i.i.d. observations from a continuous distribution  $F$  and let  $R_1, R_2, \dots, R_n$  be the ranks of the observations.

- (a) Find  $\text{Cov}(R_1, R_2)$ .  
(b) Let  $F = U(0, 1)$ . Find the correlation coefficient between  $X_1$  and  $R_1$ . [6+8 = 14]

4. Let  $X_1, X_2, \dots, X_n$  ( $n \geq 2$ ) be i.i.d. observations from a Poisson distribution with mean  $\theta > 0$ . Consider the problem of estimating  $g(\theta) = P_{\theta}(X_1 = 0)$ .

- (a) Find the uniformly minimum variance unbiased estimator of  $g(\theta)$ .

- (b) Denote the estimator obtained in (a) by  $T_n$ . Decide, with reasons, if the variance of  $T_n$  can attain the corresponding Cramer-Rao lower bound for some  $\theta$ . [7+7 = 14]

5. Suppose i.i.d. observations  $X_i$ 's ( $i \geq 1$ ) are being drawn from a gamma population with the following probability density function:

$$f(x|\theta) \stackrel{def}{=} \frac{x^{1/2} \exp(-x/\theta)}{\theta^{3/2} \Gamma(3/2)}, \quad x > 0, \theta > 0.$$

- (a) Find the MLE  $\hat{\theta}_n$  of  $\theta$  based on  $X_1, \dots, X_n$ .  
 (b) Find the asymptotic distribution of  $\hat{\theta}_n$ .  
 (c) Obtain the variance stabilising transformation for the distribution in (b) and describe how you can use it to obtain an approximate 100(1 -  $\alpha$ )% confidence interval for  $\theta$ .

[3+4+(3+4) = 14]

6. Let  $X_1, X_2, \dots, X_n$  be i.i.d. from a distribution with a common density given by  $\frac{1}{\theta} \exp(-x/\theta)$ ,  $x > 0$ ,  $\theta > 0$ . Consider the problem of testing

$$H_0 : \theta = 1 \text{ versus } H_1 : \theta = 2.$$

Let  $\omega_1$  and  $\omega_2$  be two critical regions given by

$$\omega_1 : \sum_{i=1}^n X_i \geq C_1 \quad \text{and} \quad \omega_2 : (\text{number of } X_i\text{'s} \geq 2) \geq C_2.$$

- (a) Determine approximately the values of  $C_1$  and  $C_2$  so that both tests are of size  $\alpha$  for large  $n$ .  
 (b) Show that the powers of both tests tend to 1 as  $n \rightarrow \infty$ .  
 (c) Which test would require more sample size to achieve the same asymptotic power? Justify your answer.

[5+4+5 = 14]

7. Consider a balanced two-way ANOVA model with interaction. There are three treatments, five blocks, and four observations per cell.

- (a) What are the degrees of freedom corresponding to the sum of squares due to the treatment, block and interaction?  
 (b) At most how many of the observations can be missing without affecting the estimability of any of the estimable linear parametric functions (LPFs) in the model? Justify your answer.  
 (c) What is the minimum number of observations that can be missing so that at least one of the above LPFs is no longer estimable?

- (d) Suppose  $m$  is the answer to part (c) and a particular set of  $m$  observations is missing such that at least one of the originally estimable LPFs is no longer estimable. Give an expression for the error sum of squares in such a case, along with the associated degrees of freedom.

$$[3+3+2+(4+2) = 14]$$

8. Suppose  $\mathbf{X} = (X_1, \dots, X_p)^T \sim N_p(\boldsymbol{\mu}, \boldsymbol{\Sigma})$ , where  $\boldsymbol{\mu} \in \mathbb{R}^p$  and  $\boldsymbol{\Sigma}$  are both unknown. Also,  $\boldsymbol{\Sigma}$  is nonsingular. We wish to test the hypothesis

$H_0 : X_1 \text{ and } (X_2, \dots, X_p) \text{ are independent}$  versus  $H_1 : H_0 \text{ is false}$ ,

based on  $n$  ( $n > p$ ) i.i.d. realizations of  $\mathbf{X}$ , denoted by  $\mathbf{X}_1, \mathbf{X}_2, \dots, \mathbf{X}_n$ . Denote by  $R$ , the sample multiple correlation coefficient of  $X_1$  with  $(X_2, \dots, X_p)$ . Let  $\lambda$  denote the likelihood ratio test statistic for testing  $H_0$  versus  $H_1$ .

- (a) Show that  $\lambda = (1 - R^2)^{n/2}$ .

- (b) Show that under  $H_0$ ,  $[R^2/(1 - R^2)] \cdot [(n - p)/(p - 1)] \sim F_{p-1, n-p}$ .  
[6+8 = 14]